

# Materials for Architecture and Technological Innovation (6 CFU)

## Materials Technologies for the Environment (6 CFU)

Prof. Alberto De Capua

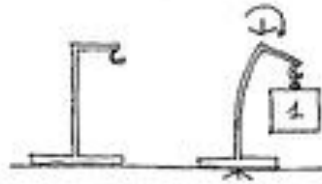
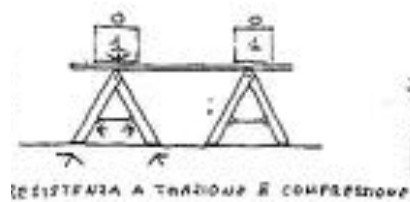
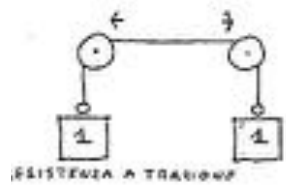
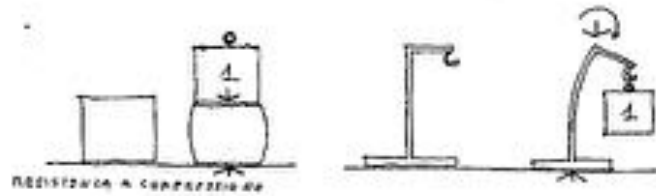

### MpA 5 Construction principles and procedures

# The constructive process

The BUILDING ORGANISM is a theoretical "constructive apparatus".

The CONSTRUCTION PROCESS is the set of works necessary to realize the Building Organization



The factors that influence the construction process are:

the workability of materials

their use in order to ensure the safety of construction

their use for environmental comfort purposes

appearance



## 1. Workability of materials

The processing principles can be simple or complex.

Simple principles are defined:

Removal (rock-cut temples, traces, earthworks, drilling, tunnels)

direct moulding (glass, earthen constructions, rod bending)

indirect moulding (concrete casting, profiling, extrusion, moulding, hygiene equipment)

Complex principles are defined:

addition and stratification (formation of triliths, prefabricated structures)

warping and weaving (large wooden or steel covers, railings)

Translated with [www.DeepL.com/Translator](http://www.DeepL.com/Translator)

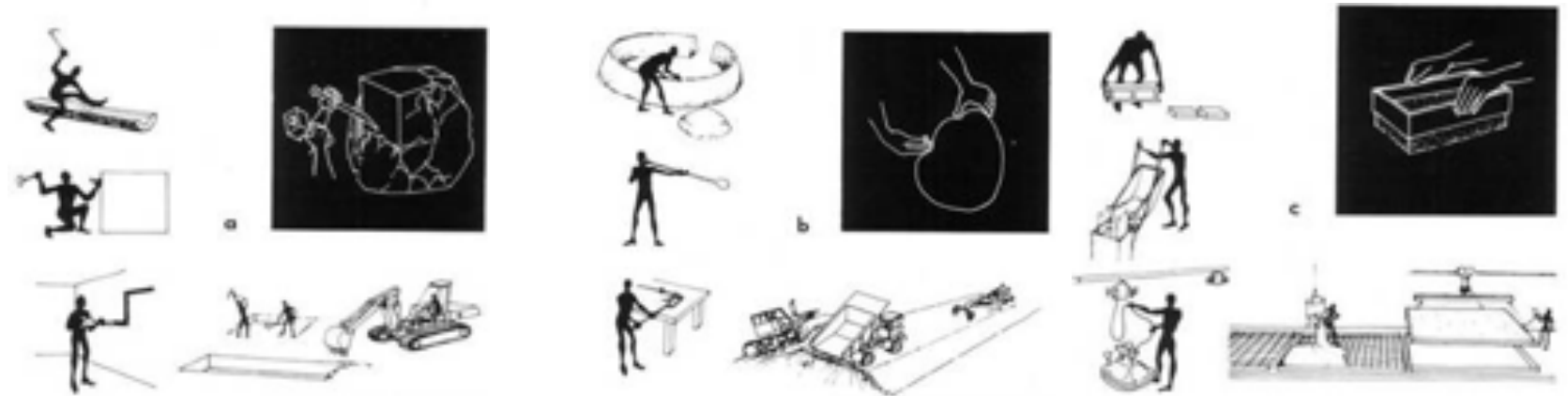



## 2. Use of materials for construction safety purposes

Identification of intuitive principles and analytical procedures so that the construction parts can withstand the stresses to which they are subjected.

The problem has a twofold aspect deriving from the theory of resistance:

need for external equilibrium (stability)

need for internal balance (resistance)

The first depends on the degrees of freedom of the elements (the material is irrelevant).

The second is closely related to the strength of the material.

### The principle of «Trilte»

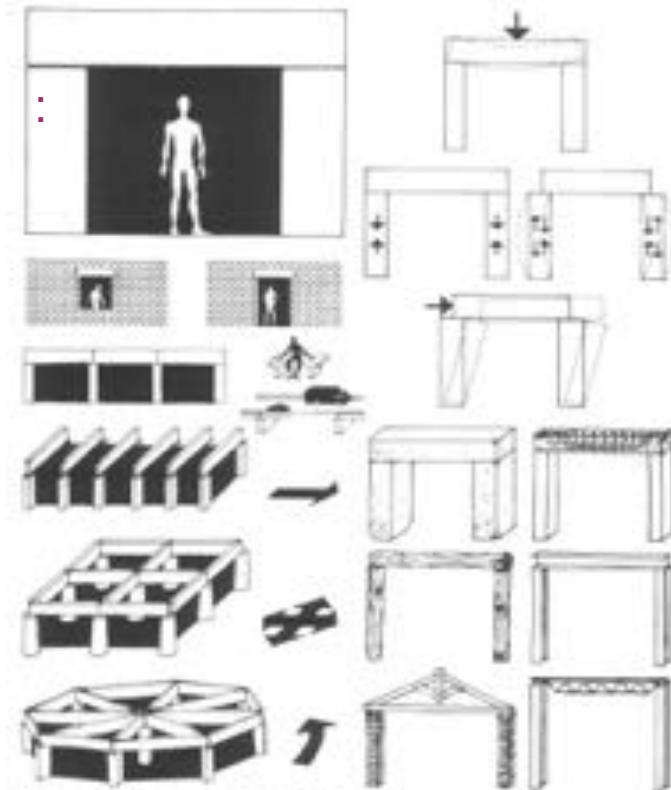

### The principle of Frame"

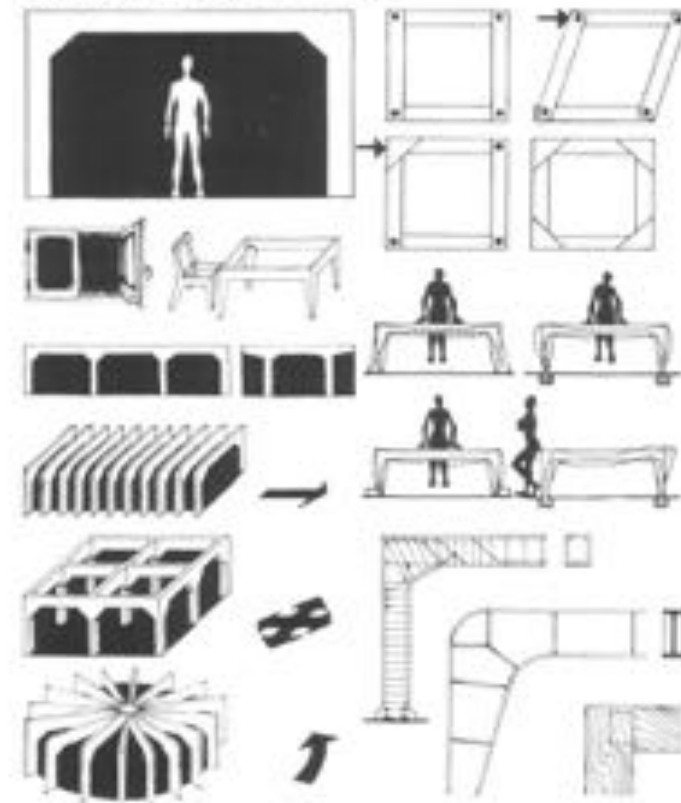

## The principle of «Trilte»

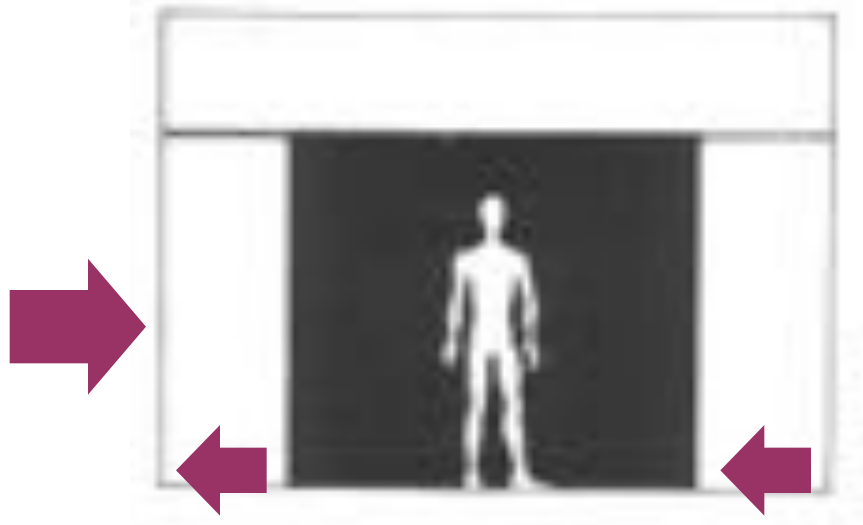
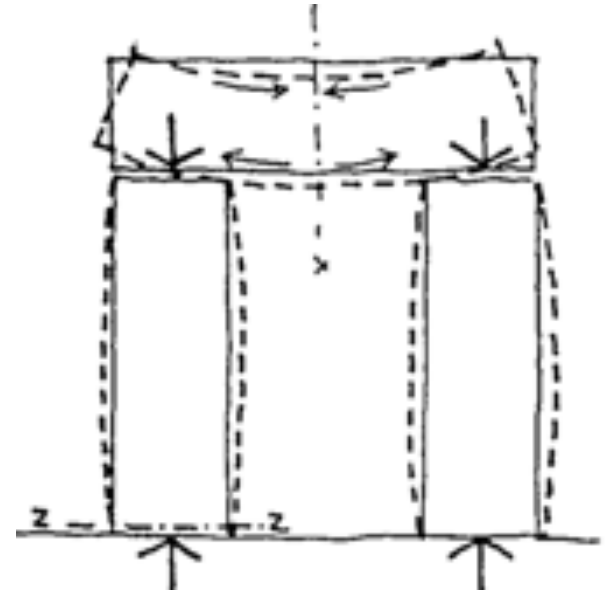
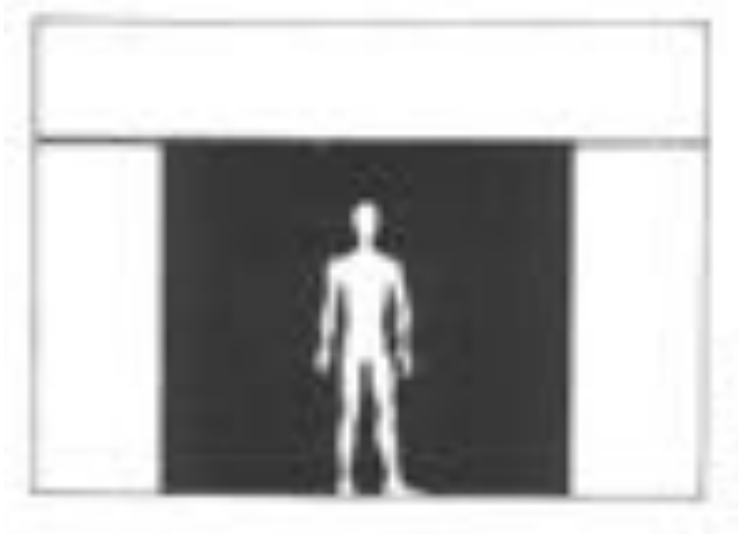

Scroll check

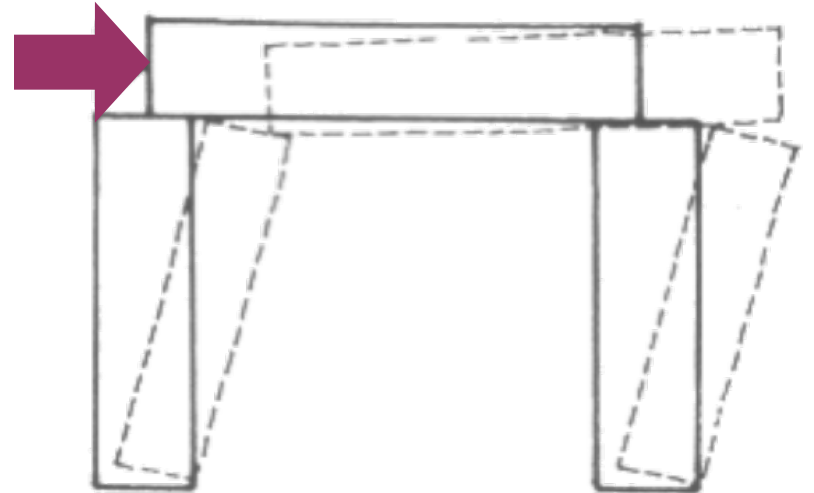

Tilting check

## The principle of «Trilte»

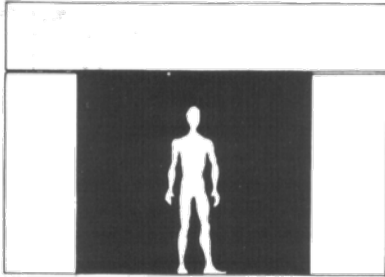

### Lintel reinforcement:

1. Increased section
2. Damping (reduction of structural width)
3. Discharge triangle

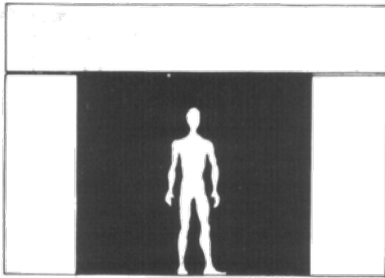

### Reinforcement feet:

1. Increased section
2. Basic enlargement
3. Dampening

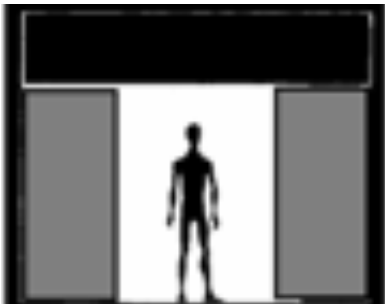

# The principle of Frame"

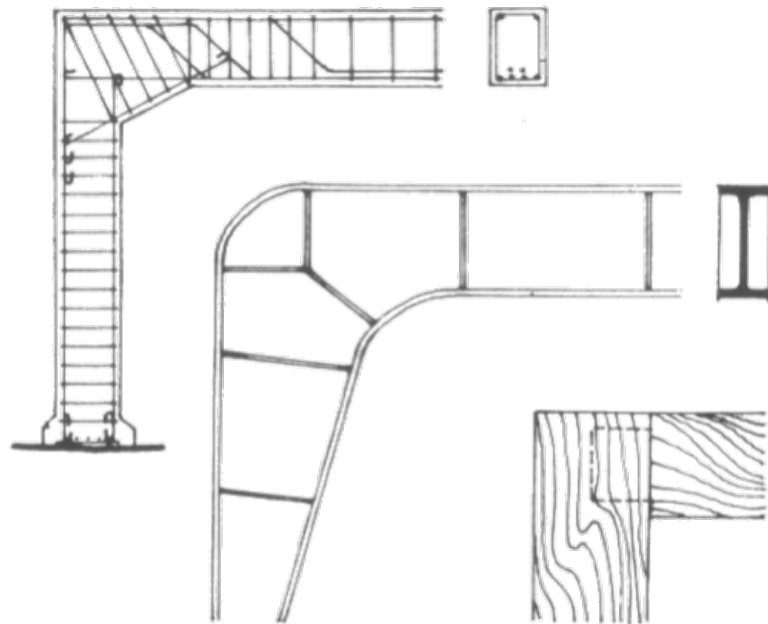
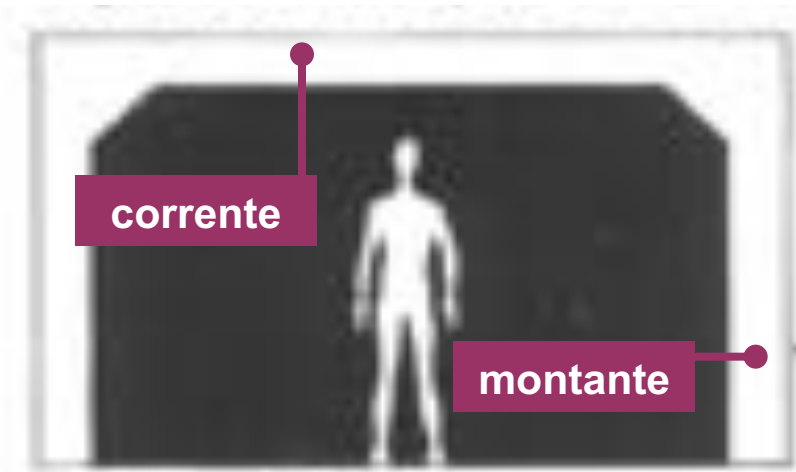

Joints: reinforced concrete, steel and wood frames

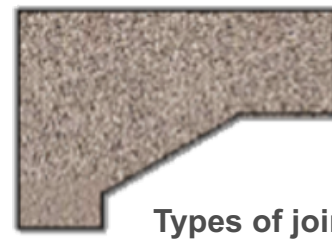
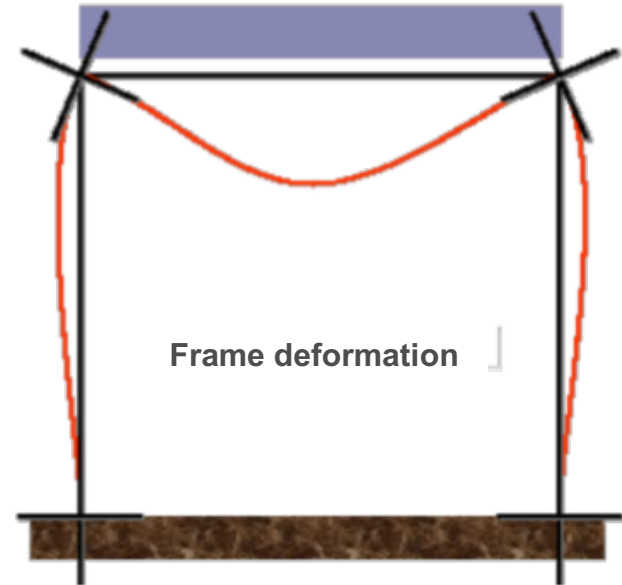

Types of joint

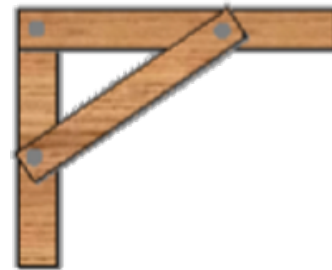

## Principle of the Arch

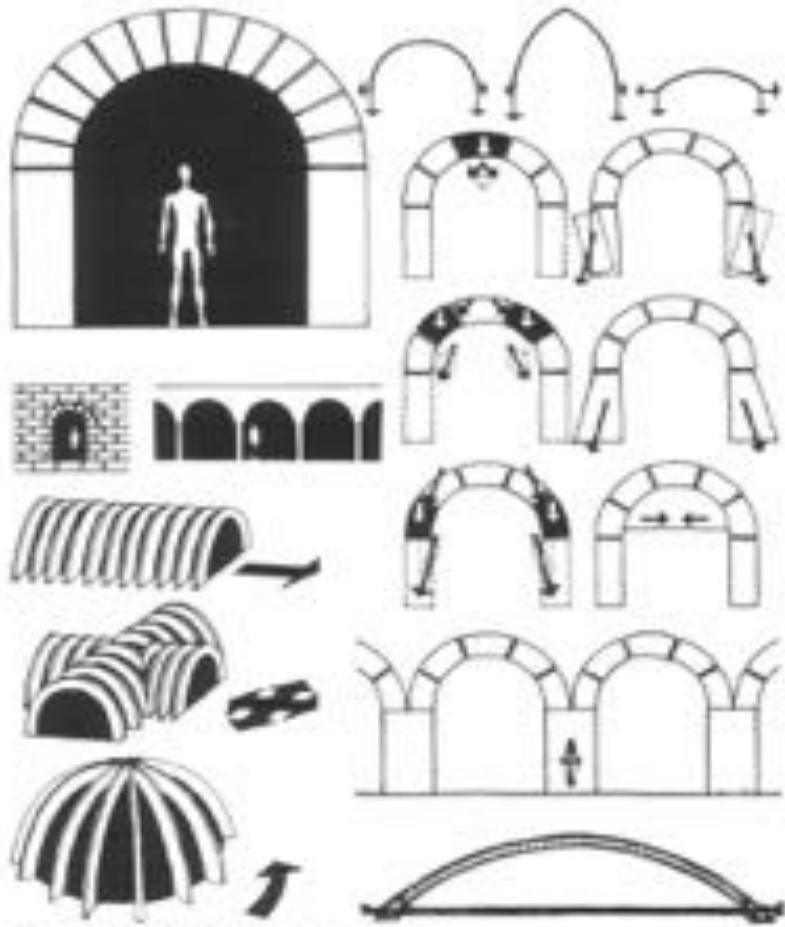

## Principle of the Cable

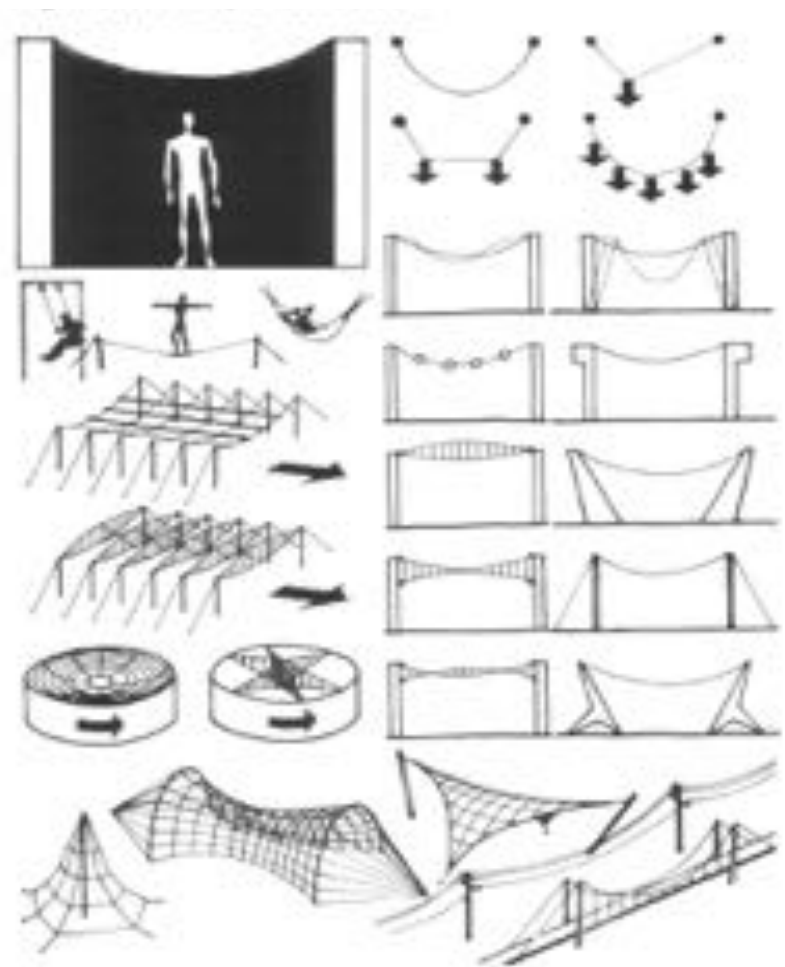



## The principle of Arch

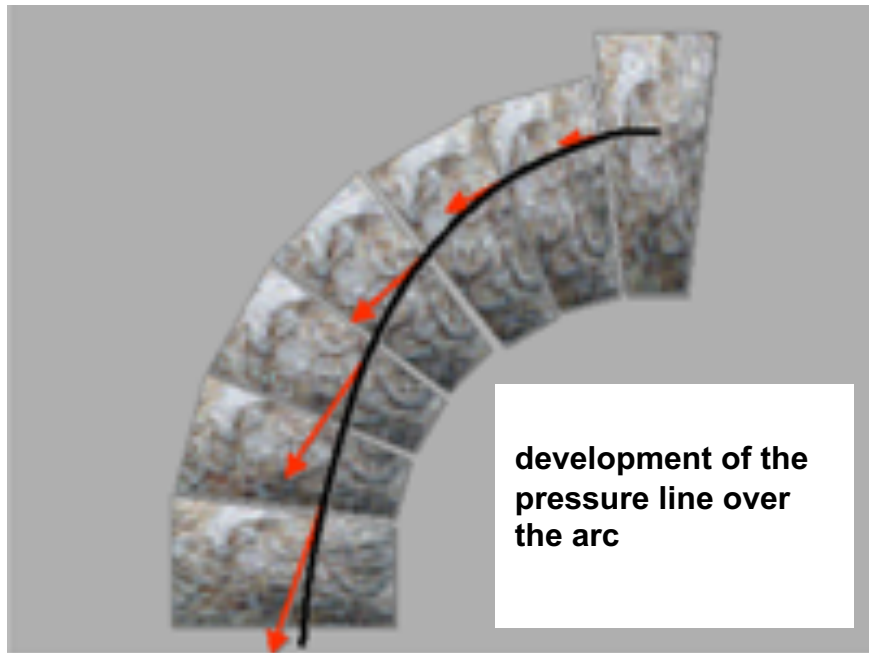
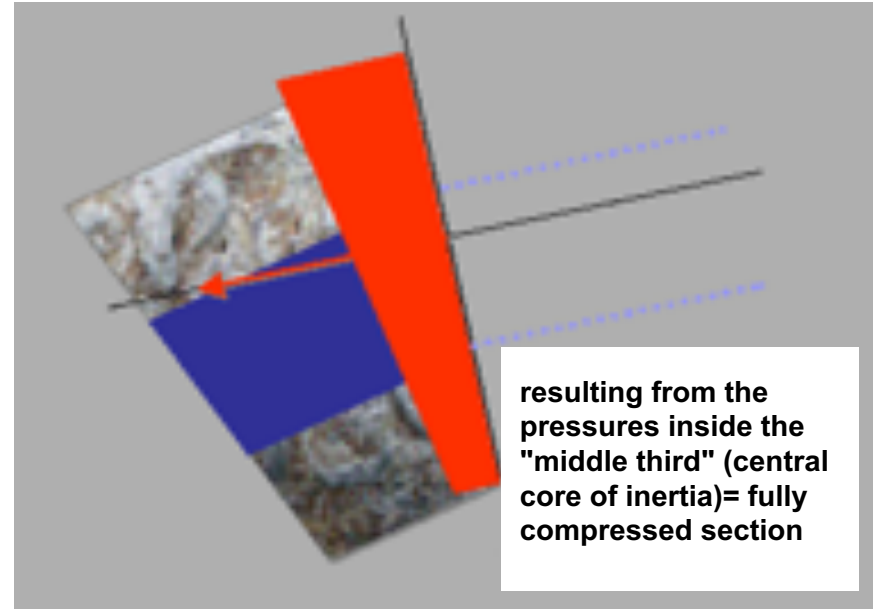
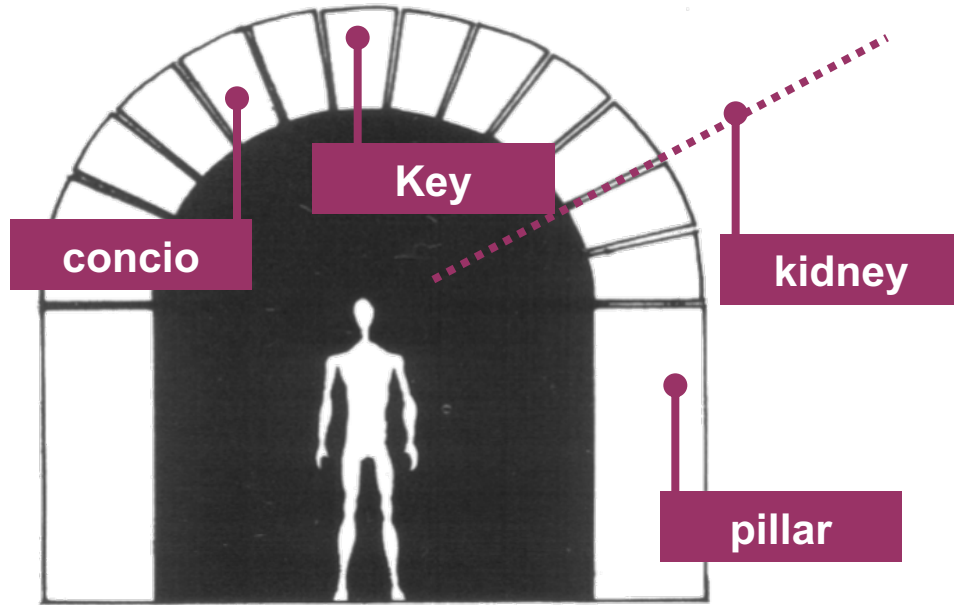

# Principi complessi: I "arco"

Stabilization of the pillars

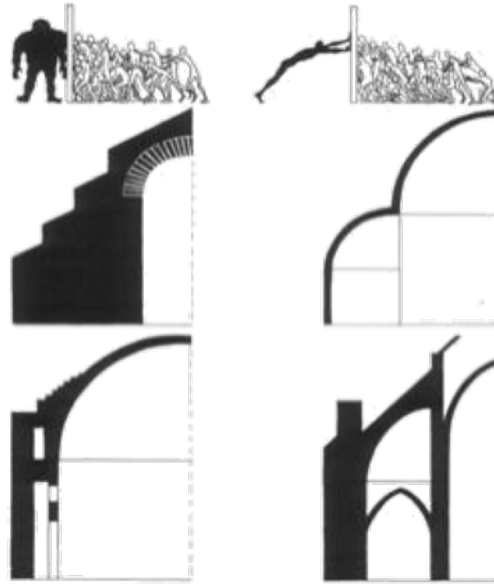
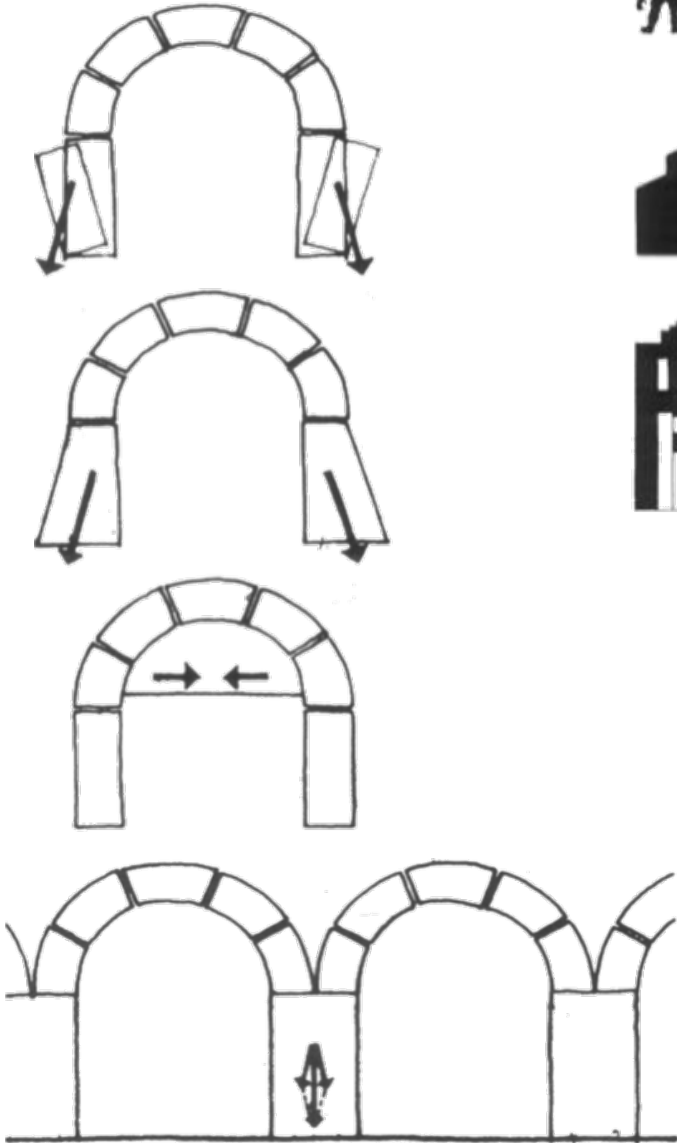

Passive and active resistances

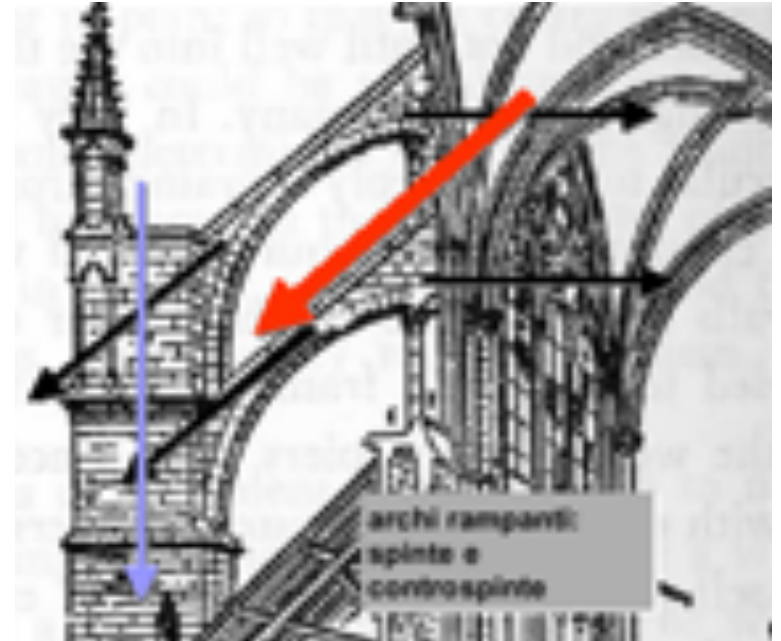

Pushing arcs eliminated with chain



# The Principle of Cable

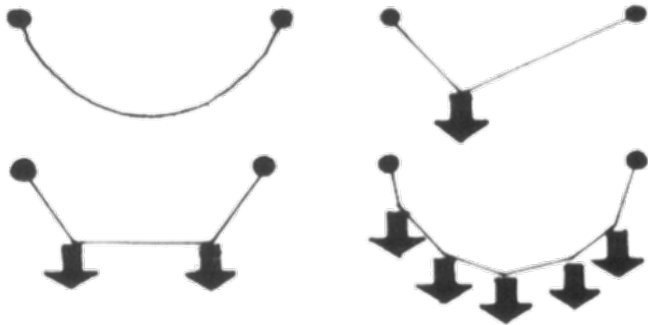
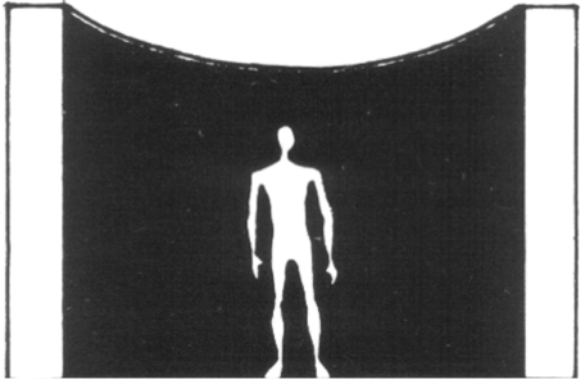

pattern

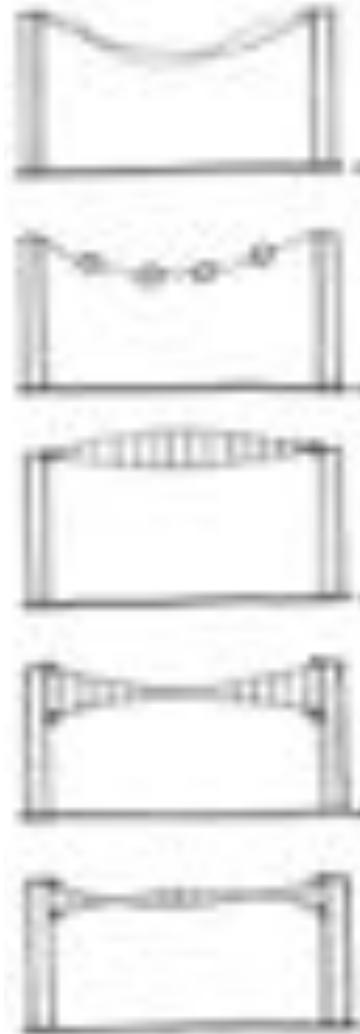

stability

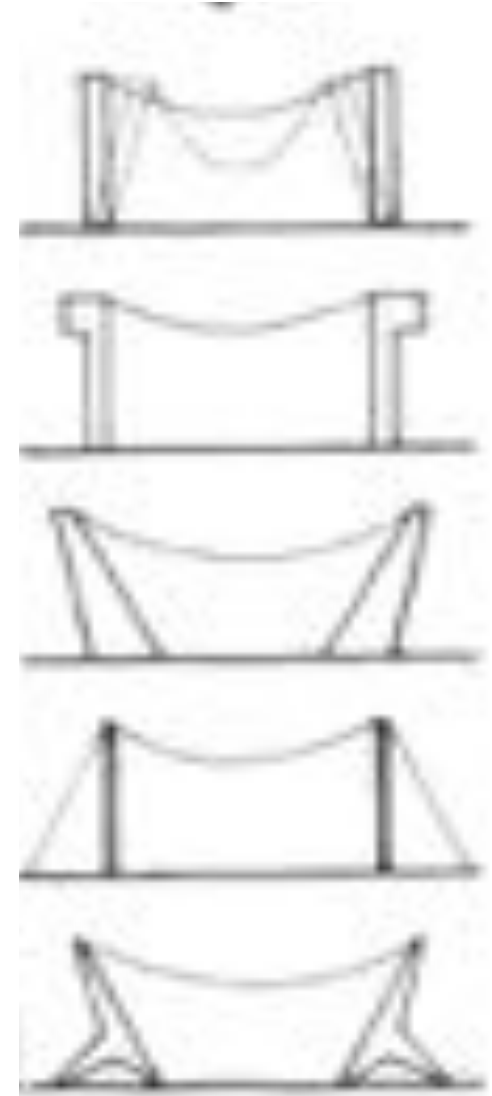

pillars

# The Principle of Cable

Stability of pillars

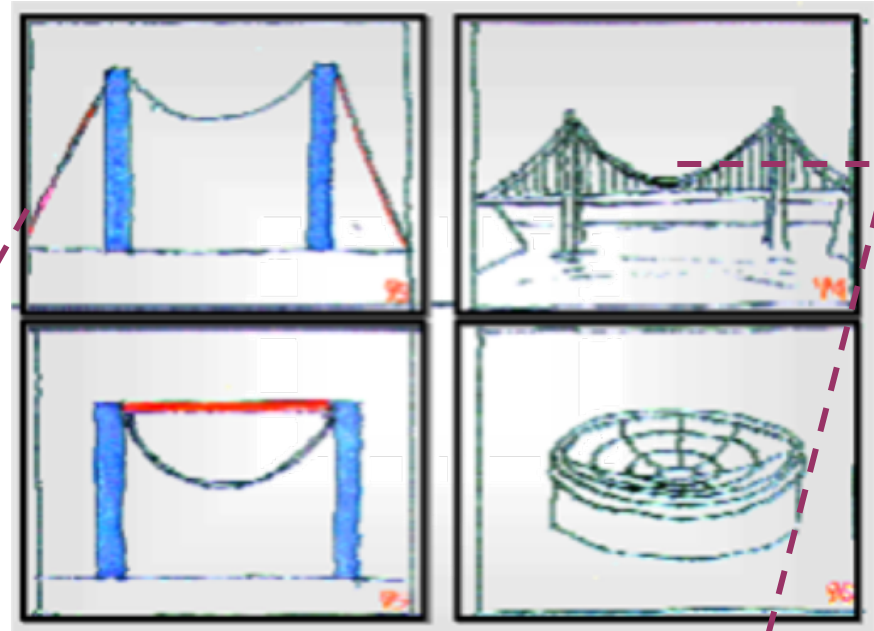
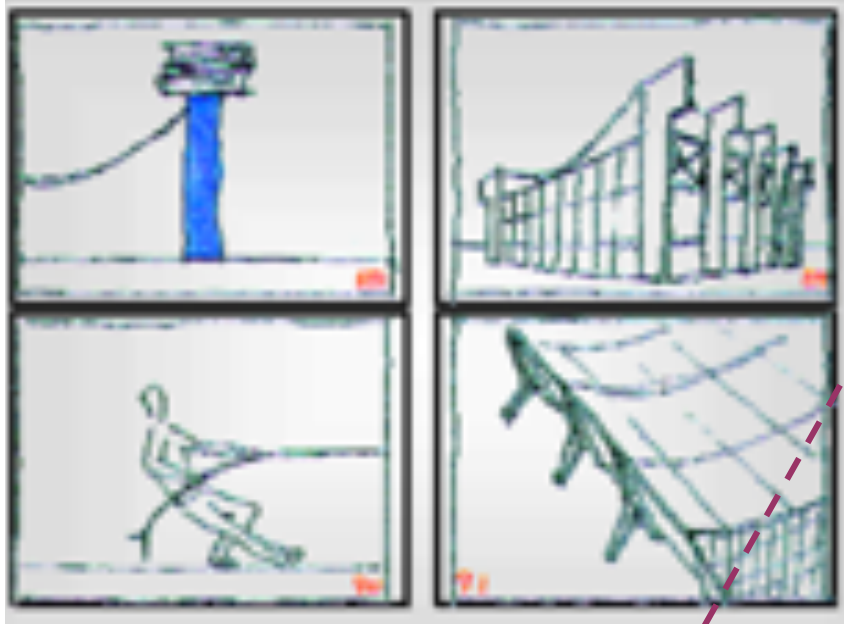

### The principle of Triangle



### The principle of Fungus

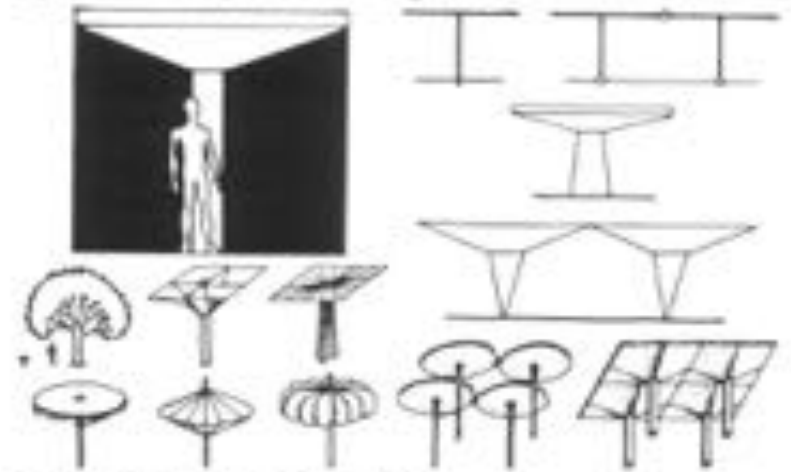

### The principle of Pneumatic

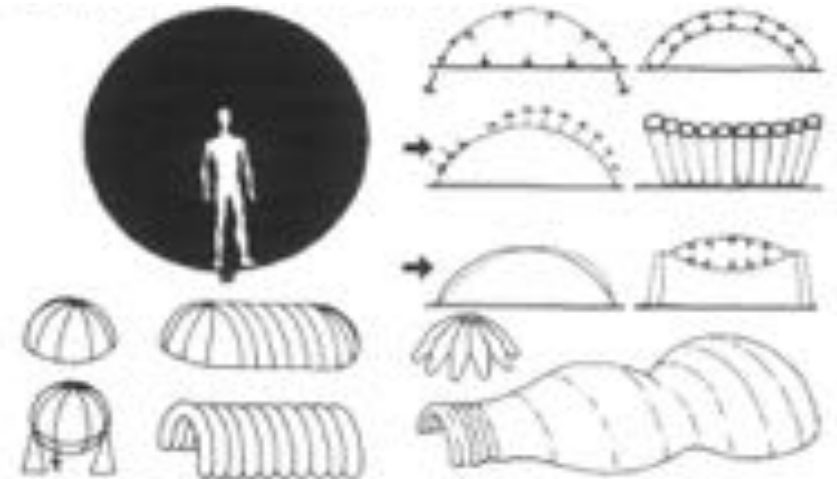

## The principle of Triangle. Examples

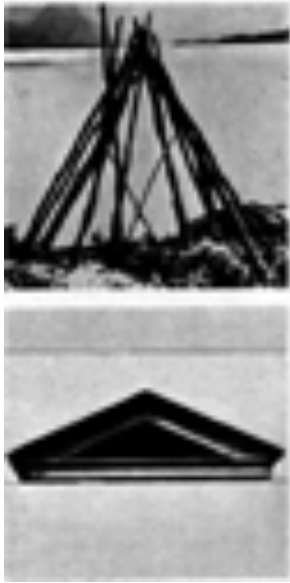

Hut-shaped global envelope organisms



Gable cover



Truss

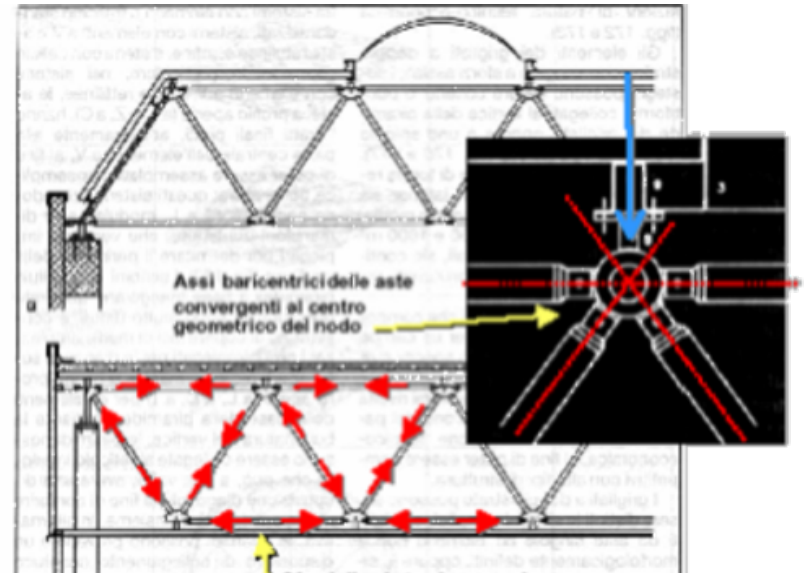

Reticular elements

## The principle of Fungus



## The principle of Pneumatic

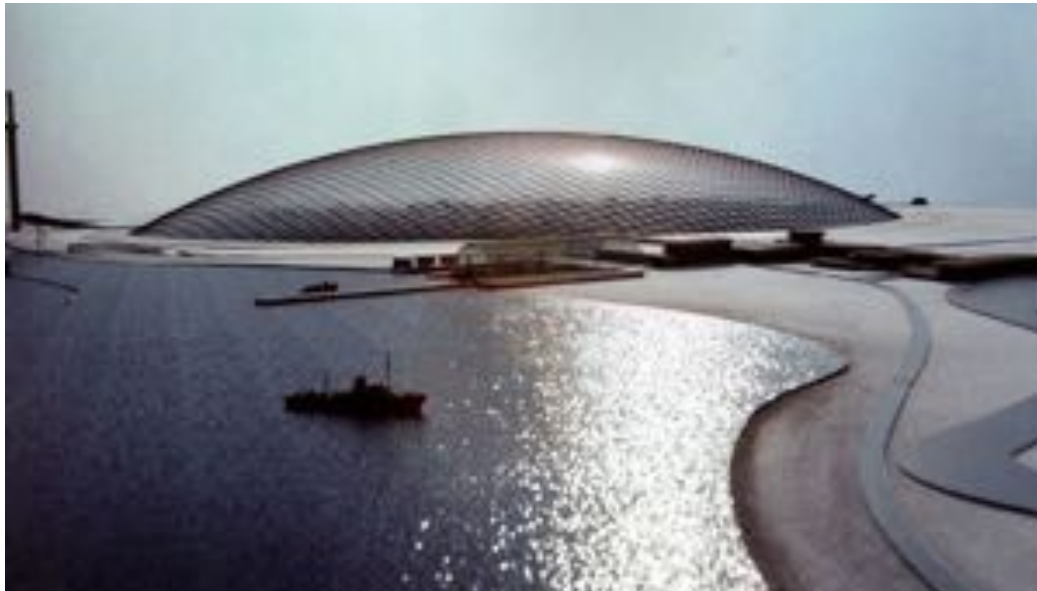

City in the Arctic, 1971, Frei Otto



Nuovo stadio di Monaco, 2006, Herzog e DeMeuron

## Stress to deformation ratios



## Resistance by shape

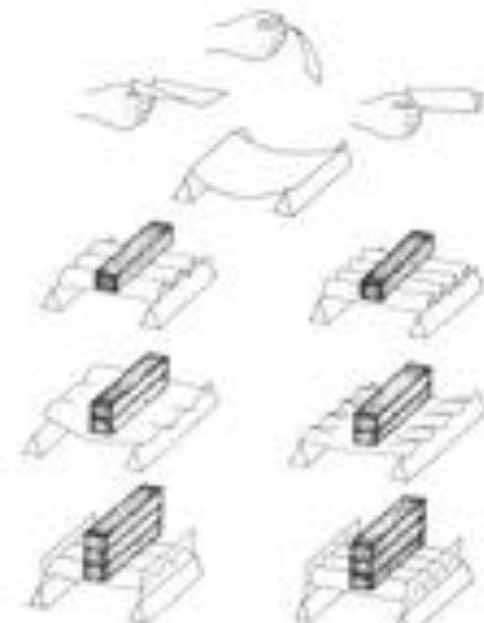

## Passive and active resistances

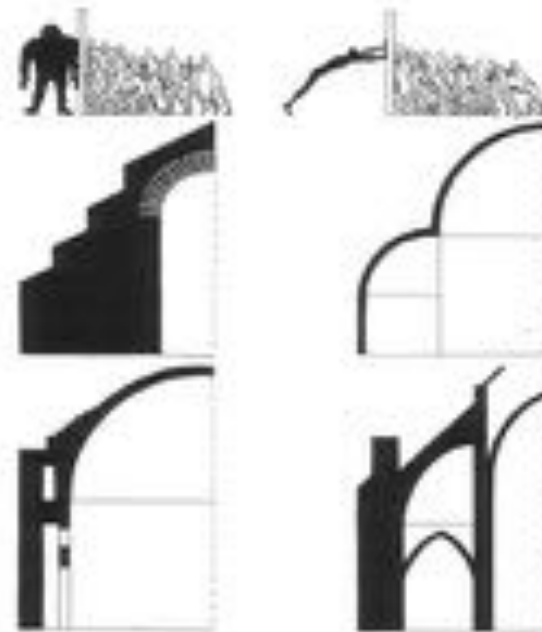



### 3. Use of materials for environmental comfort problems of protection from atmospheric agents and soundproofing

With regard to the protection from atmospheric precipitation, two principles are distinguished that affect the shape of the building:

principle of direct flow (roof or vault)

principle of collection and disposal (terrace roofing)

With regard to thermal and acoustic insulation, they stand out:

The single-body principle (single-material construction element)

the principle of the multiple body (elements made up of several materials with complementary roles)

The following measures can be taken to protect against water and air infiltration:

Reduce the number of joints

carry out waterproofing surf



**Principle of direct outflow**  
**Collection and disposal" principle**

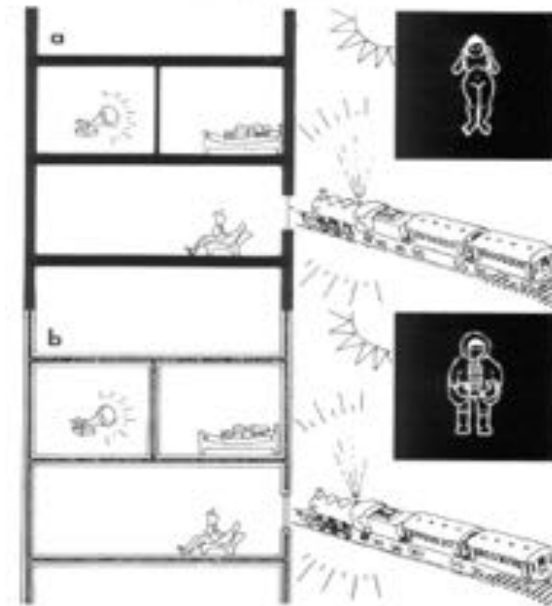

**Principle "of the one body"**  
**Principle "of the multiple body"**

## ➔ 4. Appearance of materials

Two principles can be distinguished:

Material principle (material elements left in sight);

Geometric principle (surface and volume, use of plaster, paints).

The two principles can still coexist.

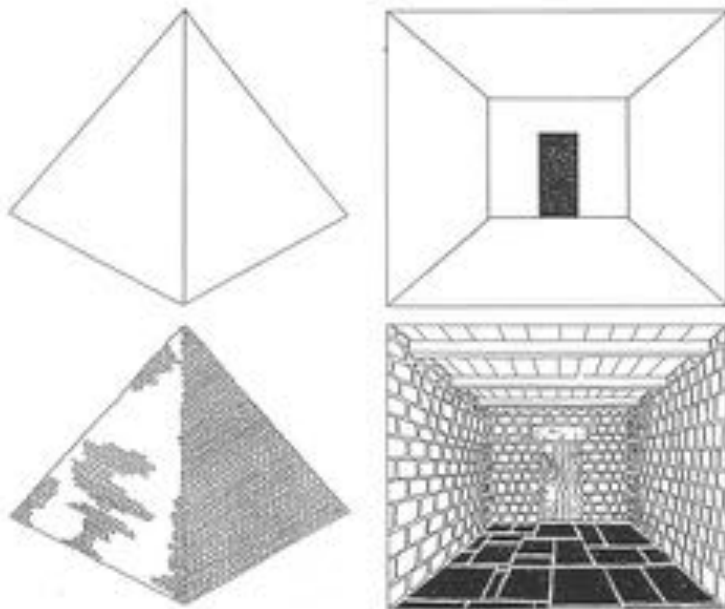

**Geometric principle and material principle**



## The material and the perception of the form

